

---

## KJ-66 micoturbine

---

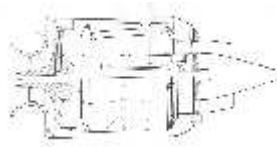

### Specification

Diameter	110mm
Length	235mm
Thrust	was 33 Newtons, now 50 (11 lbs)
Max revs	103,000 rpm
Temp	550 deg C
Weight	1.140 KG
Lubrication	Separate oil tank

---

### Design

The KJ-66 engine around a KKK turbocharger compressor No 2018. This has 2 advantages, the compressor is readily available in reasonably well balanced condition and it can withstand higher rpm than it will encounter in the engine. The construction is similar to the FD3 64 except that all materials are metal. The turbocharger revolves in a clockwise rotation and this means that then securing nuts for the shaft are left hand thread. In the book Thomas described the way to make a hollow shaft. Though an elegant solution to weight and strength it is difficult to make. The outer can is fabricated but with some ingenuity the same gas cylinder that is used for the FD3 64 could be used.

This engine represents major advance over the FD3 64 and has been further developed to produce 50 Newton thrust (11 lbs). It will run reliably with the revised chamber at a temperature of 550 deg C or cooler.



## Materials

The whole of the front of the engine is aluminium. The diffuser vanes are made separately and glued in place with epoxy glue. The front cover could be spun aluminium or turned from solid aluminium. The main shaft is made from tough steel to UK spec EN24T. This is in hardened condition and must be accurately turned between centres or precision ground. The NGV assembly and the rear cone is Stainless steel to UK spec 316 or 310.



The combustion chamber is also of the same material but .5mm thick. The bearings are 22mm x 6mm with 8mm bore ISO 608 C3 spec for the front bearing and 16mm x 6mm with 8mm bore for the rear.



## Turbine wheel

This differs from the FD3 64 and is made from 6mm thick stainless steel. It has a hole through the boss and is secured with a left hand thread nut. The blades are twisted and profiled by hand as in the FD3 64





---

## Improvements to the design

1. The Combustion chamber - Thomas has revised the chamber to feed the fuel in from the rear of the chamber via slightly bent sticks. The rest of the chamber design is as in the book and drawings are available in the back copies of the newsletters. The fuel can be fed from the front of the engine to a circular manifold at the rear. Separate gas and fuel feeds are now usually fitted.
2. Turbine wheel - The turbine wheel has been revised from the original twisted stainless steel wheel. The best results come from the cast Inconel wheels of Jesus Artes. However revised drawings for the home ground wheel are also available in the newsletter and they produce a big improvement in thrust.
3. The shaft bearings and bearing tube - The bearings in the book are not preloaded. Angular contact at all times with the raceways is not maintained. Thomas has issued drawings in the newsletter of a new shaft tube with preloaded bearings made of aluminium and fitted with the same large bearing used in the front bearing.
4. Compressor wheel - There is an alternative to the KKK compressor specified and is made by Holsett. It is detailed in the newsletter.

---

## Kamps Micro turbine

This is a well thought out design and with the latest mods is capable of a performance better or equal to many of the commercial designs for a fraction of the cost. The combustion chamber is particularly good and can produce the low EGT temperatures that we like to see. The availability of cast turbine wheels and off the shelf compressors makes it possible for most to construct a successful engine. Parts are now available and derivative engines are being developed..

120,3

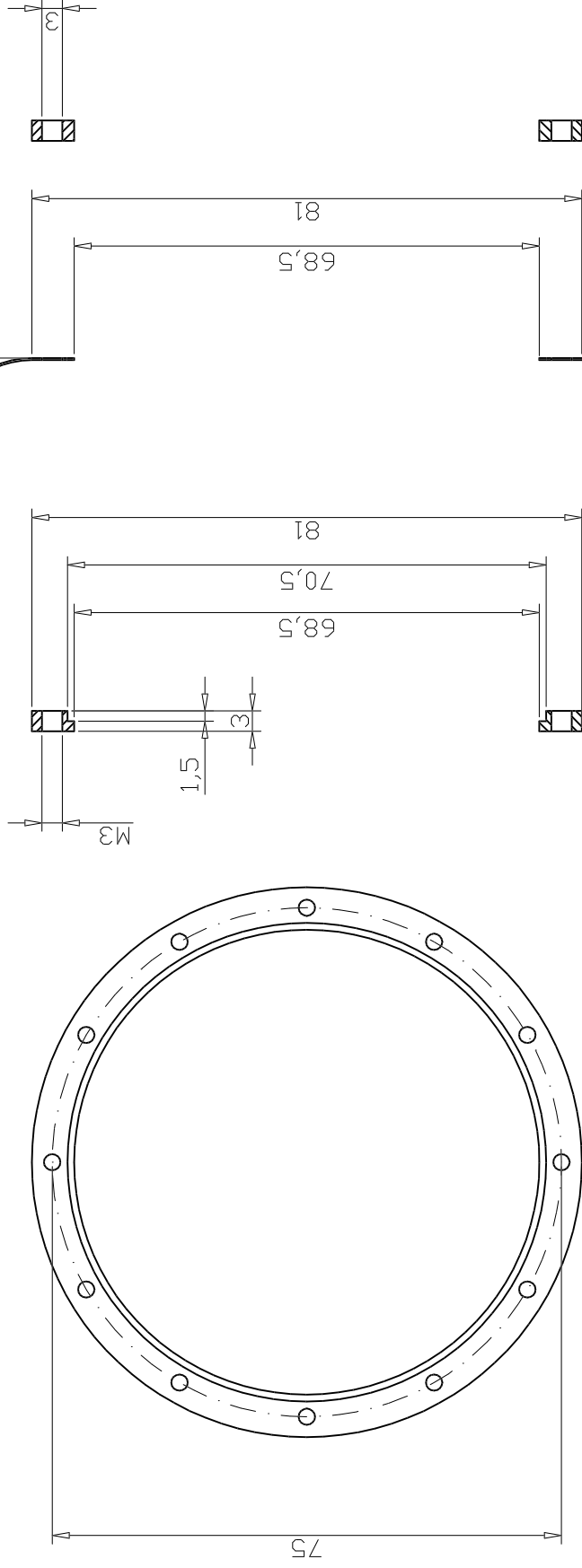

PROJEKT

Turbine T 66

NAME

Gehäuse/Flansch

GRÖÖE

A4

FSCM NO.

MATERIAL

Gaskartusche

MAÖSTAB

1mm = 1mm

DATUM

BLATT 1/1

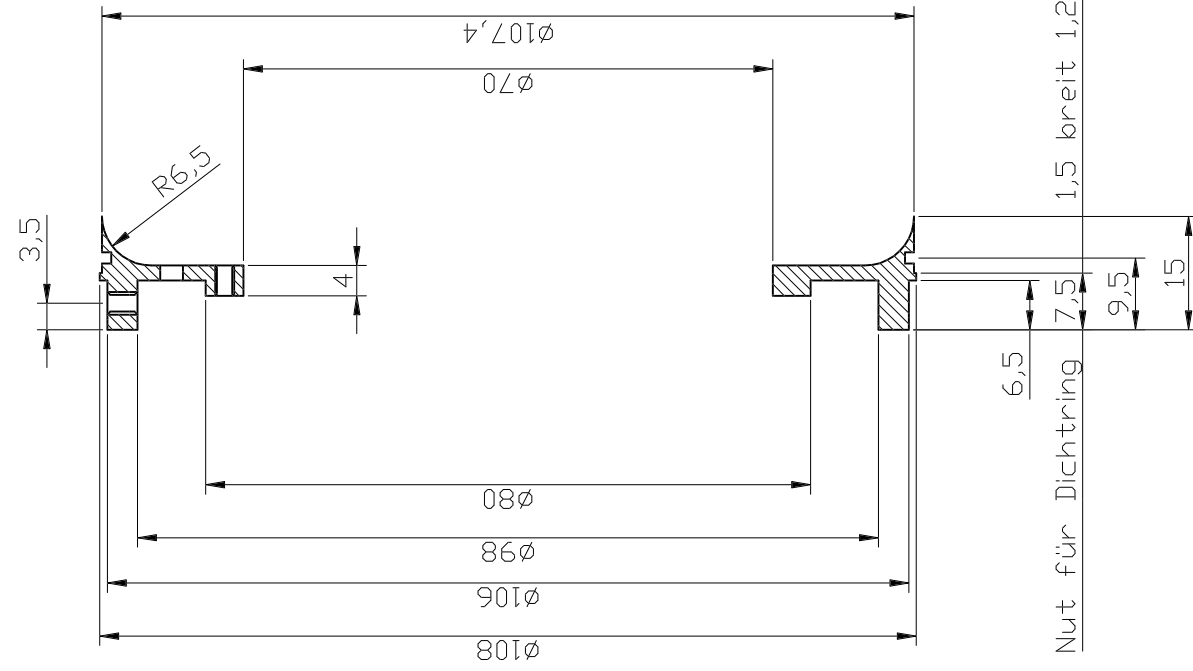
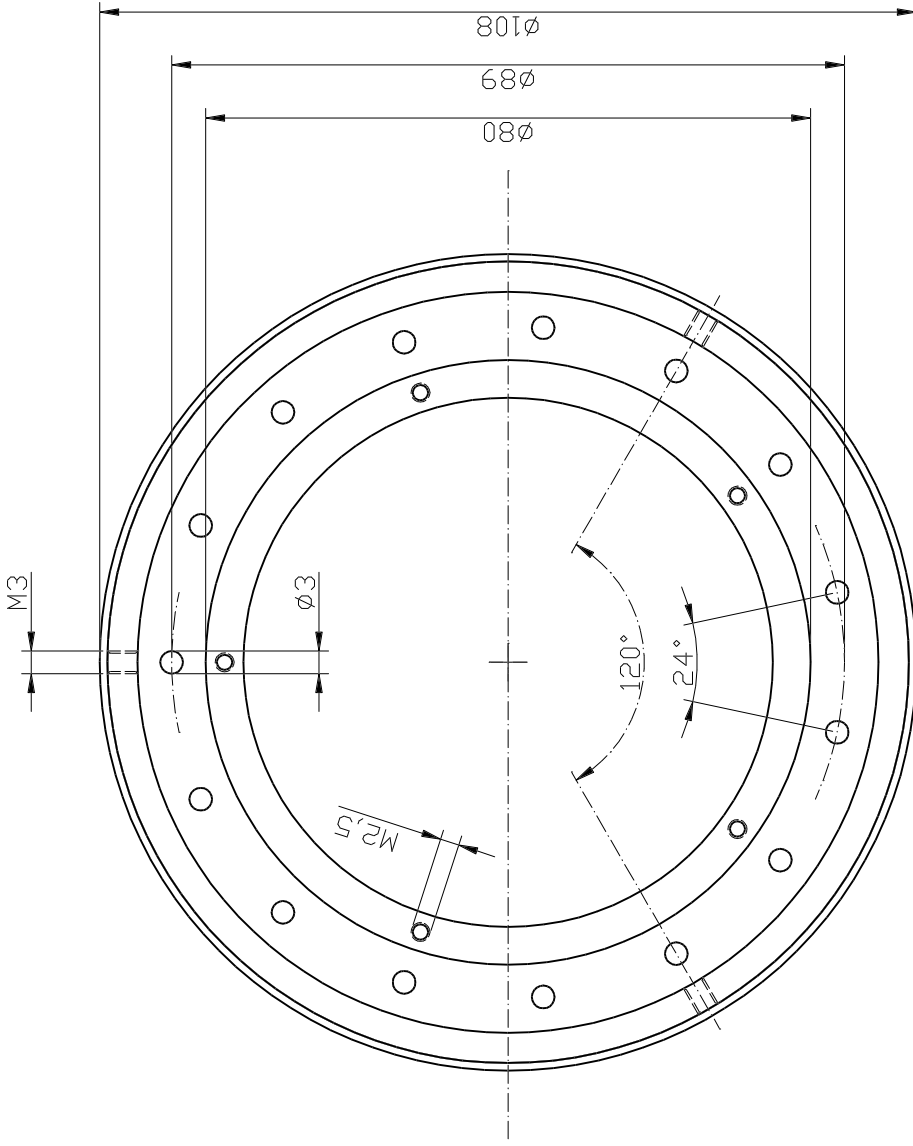

PROJEKT

Turbine T 66

NAME

Außenring

GRÖßE

A4

NORM

MATERIAL

Aluminium

MAßSTAB

1mm = 1mm

DATUM

17.02.2001

BLATT-NR

1 of 1

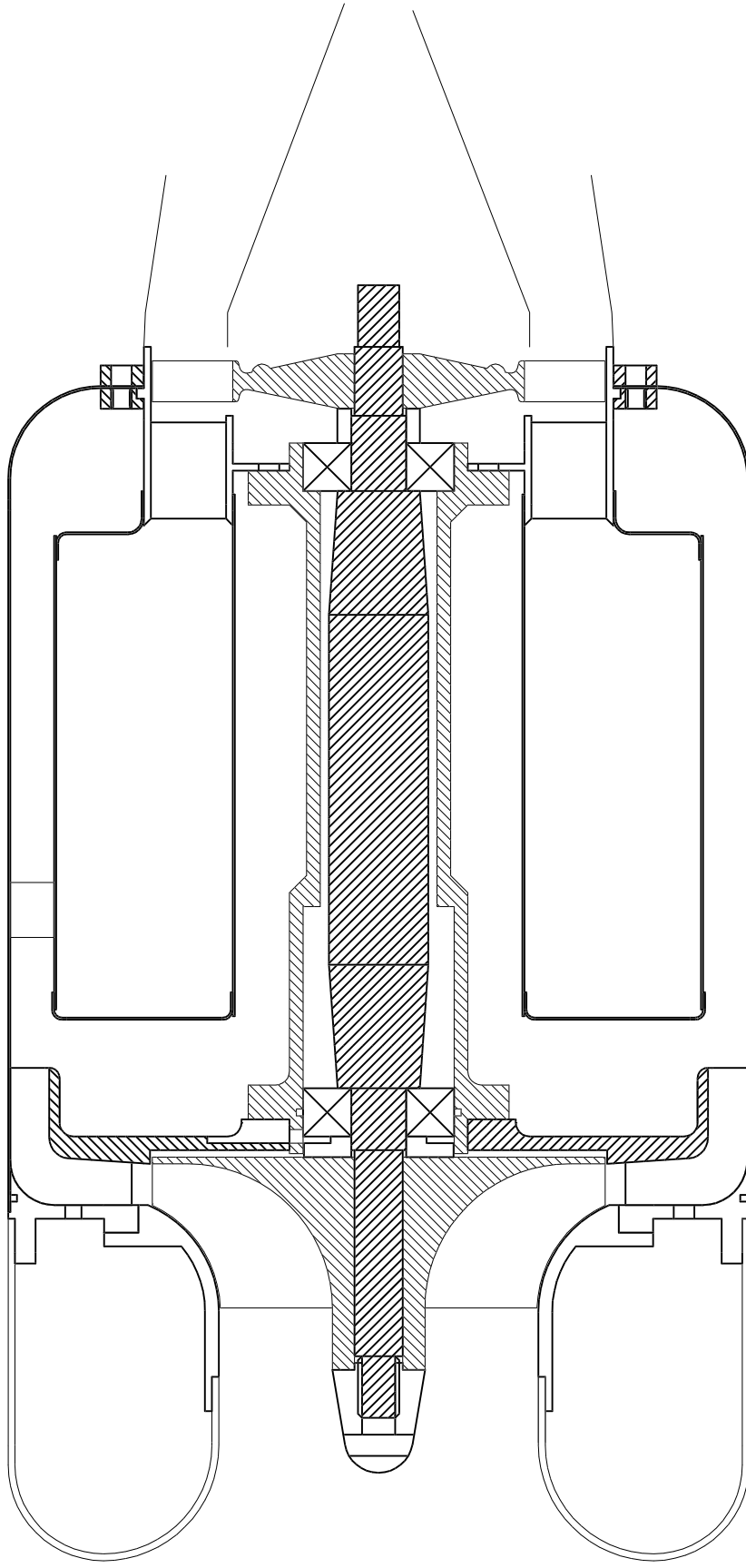

PROJEKT

Turbine T 66

NAME

komplett

GRÖÖE FSCM NO. MATERIAL

A4

MAÖSTAB 1mm = 1mm DATUM

BLATT 1 of 1

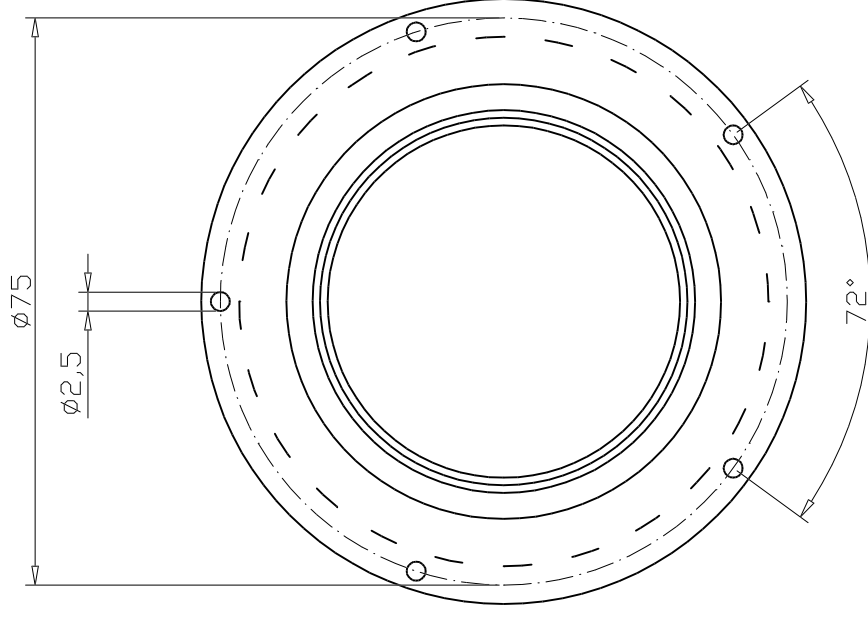
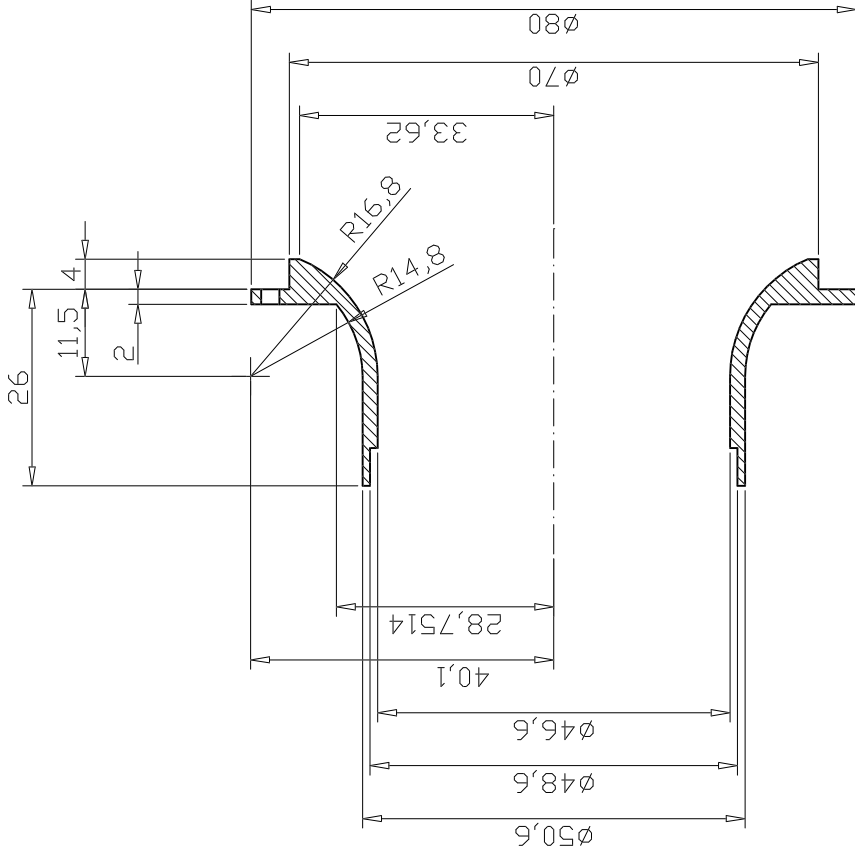

PROJEKT

Turbine T 66

NAME

Verdichterdeckel

GRÖÖE

A4

FSCM NO.

MATERIAL

PET, Delrin o. Alu

MAÖSTAB

1mm = 1mm

DATUM

BLATT

1 of 1

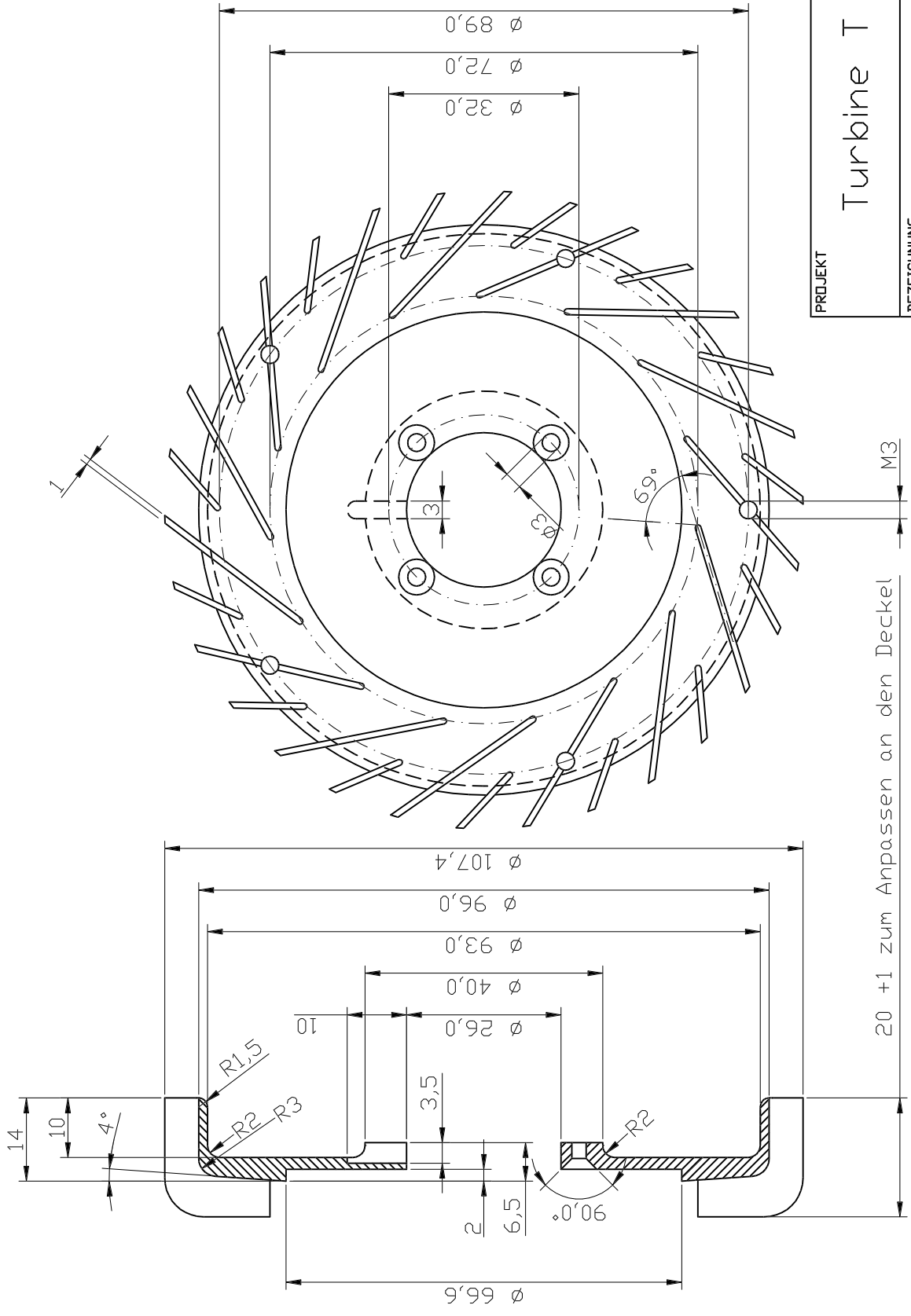

PROJEKT			
Turbine T 66			
BEZEICHNUNG			
Verdichtersystem			
GRÖÖE	FSCM NO.	MATERIAL	BLATT
A4		Alu	1/1
MAÖSTAB	DATUM		
1mm = 1mm			



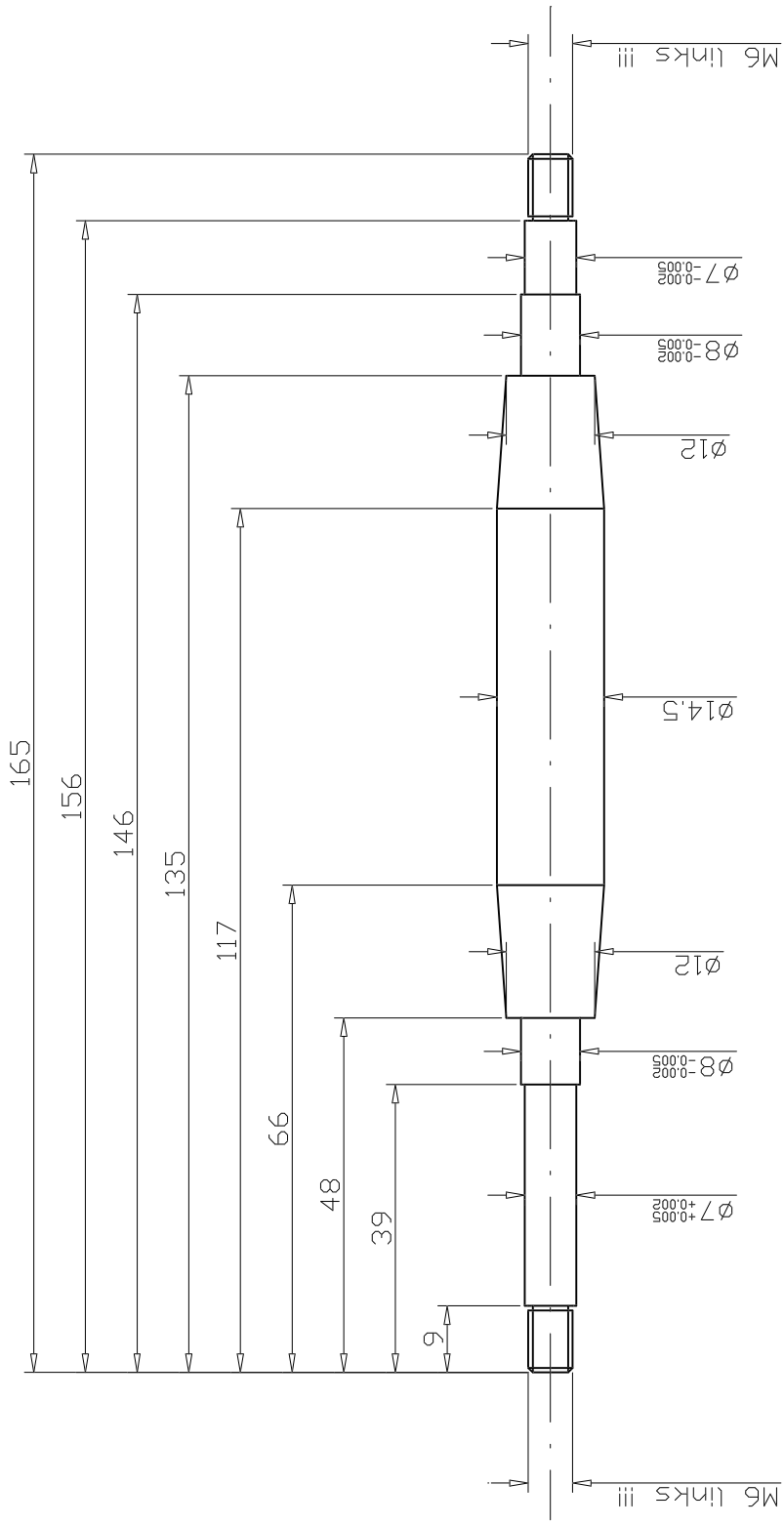

PROJEKT

Turbine T 66

NAME

Welle

GRÖÖE

A4

FSCM NO.

MATERIAL

Impulschraube  
M16x180 12.9

MAÖSTAB

1mm = 1mm

DATUM

BLATT

1 of 1

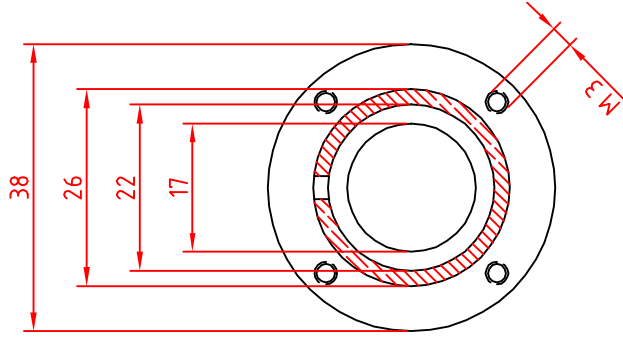
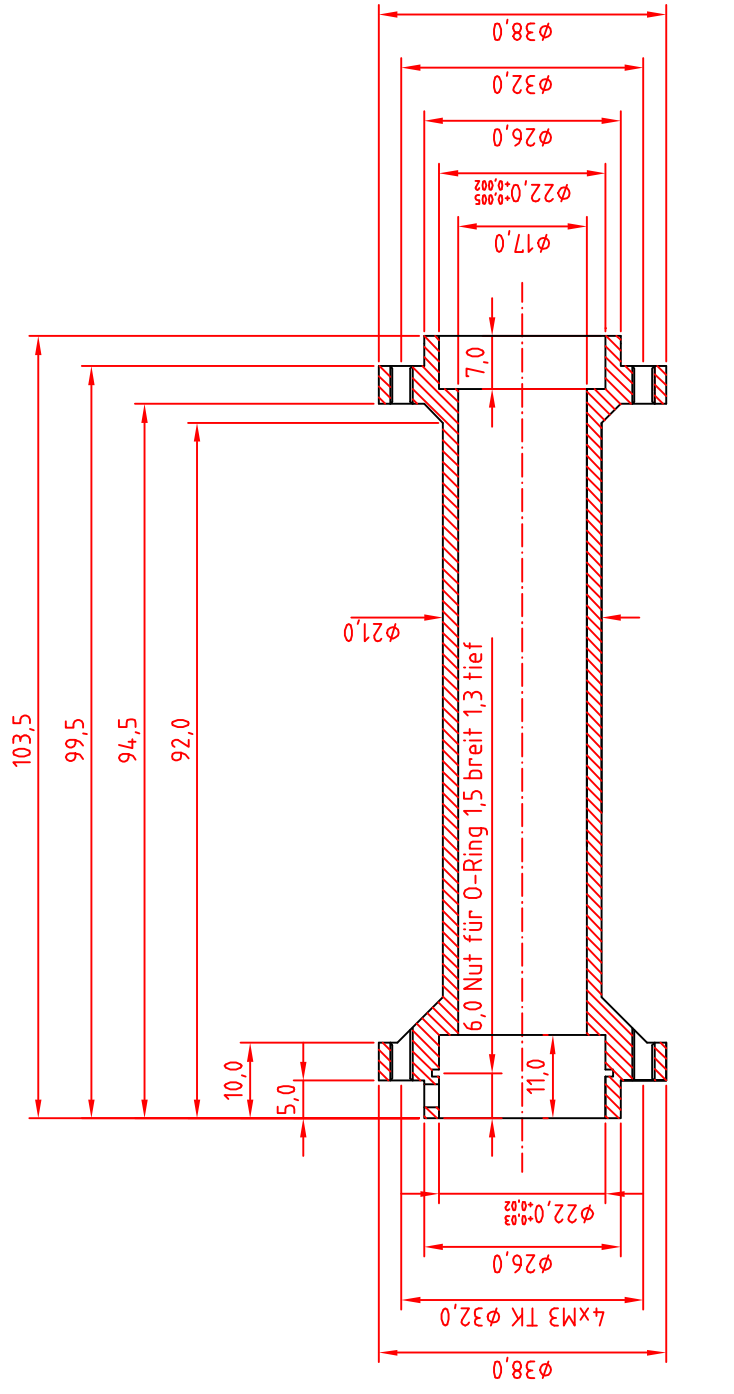

PROJEKT

Turbine T 66

NAME

Wellentunnel

GRÖÖE

A4

FSCM NO.

MATERIAL

MAÖSTAB

1mm = 1mm

DATUM

BLATT

1 of 1